



MODELS: 3MPF201/3MPF301

APPLICATION: Advanced Whole House Filtration

The 3M™ Advanced Whole House Filtration System Models 3MPF201 & 3MPF301 are large capacity systems for Well Water (3MPF201) or City Water (3MPF301) designed to filter water used throughout your entire home. The unique system design allows for fast and easy replacement filter change-outs. In addition to helping appliances and fixtures, model 3MPF301 also helps improve the taste and smell of your water by reducing chlorine taste and odor as it enters your home.

PRODUCT BENEFITS:

- Reduces sediment to help provide cleaner, clearer water. 3MPF301 also reduces chlorine taste and odor.
- Corrosion resistant stainless steel head.
- 1" NPT inlet and outlet connections for easy installation.
- Tested and rated to 20 gpm (75.7 lpm) peak flow rate, meeting most residential and light commercial applications.
- Easy to maintain, filter change is a twist.

PRODUCT SPECIFICATIONS:

Model/Part Number	Reduction Claims	Inlet/Outlet Size	Dimensions (Ht. x Dia.)	Approx. Weight	Service Flow Rate	Temperature Range	Pressure Range	Degree of Filtration	Replacement Filter
3MPF201	Sediment	1" NPT	25.1" x 4.5" (63.7 cm x 11.4 cm)	7.0 lbs. (3.2 kg)	20 gpm Peak Flow (75.7 lpm)	40 - 100°F (4.4 - 37.8°C)	25 - 125 psi (172 - 862 kPa)	5 Micron Nominal	3MPF211
3MPF301	Sediment, Chlorine Taste and Odor	1" NPT	25.1" x 4.5" (63.7 cm x 11.4 cm)	7.5 lbs. (3.4 kg)	20 gpm Peak Flow (75.7 lpm)	40 - 100°F (4.4 - 37.8°C)	25 - 125 psi (172 - 862 kPa)	5 Micron Nominal	3MPF311HD

To obtain additional information please call our Customer Care team at 855-3M-WATER or visit our website at www.3MWater.com

INSTALLATION DIFFICULTY



Skills Needed: (Please refer to installation difficulty chart on website for additional information)

- Professional installation required

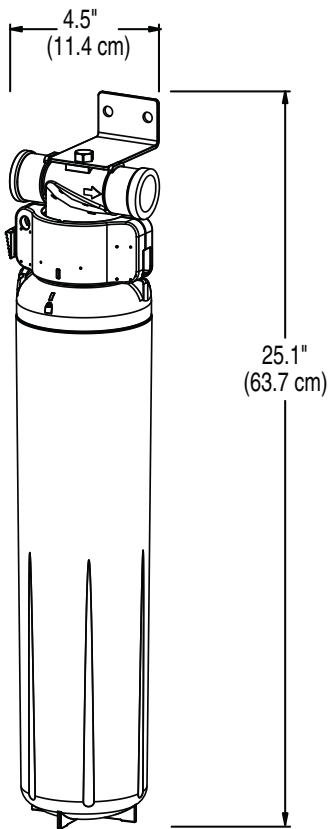

LIMITED WARRANTY

3M Purification Inc. warrants this Product will be free from defects in material and manufacture for the following periods from the date of purchase. Ten (10) year for the Product, except for the replacement filter cartridge, which is warranted for one (1) year. This warranty does not cover failures resulting from abuse, misuse, alteration or damage not caused by 3M Purification Inc. or failure to follow installation and use instructions. No warranty is given as to the service life of any filter cartridge or membrane as it will vary with local water conditions and water consumption. **3M PURIFICATION INC. MAKES NO OTHER WARRANTIES OR CONDITIONS, EXPRESS OR IMPLIED, INCLUDING, BUT NOT LIMITED TO, ANY IMPLIED WARRANTY OR CONDITION OF MERCHANTABILITY OR FITNESS FOR A PARTICULAR PURPOSE OR ANY IMPLIED WARRANTY OR CONDITION ARISING OUT OF A COURSE OF DEALING, CUSTOMER OR USAGE OF TRADE.** If the Product fails to satisfy this Limited Warranty during the warranty period, 3M Purification Inc. will replace the Product or refund your Product purchase price. This warranty does not cover labor. **The remedy stated in this paragraph is Customer's sole remedy and 3M Purification Inc.'s exclusive obligation. For additional information, see the entire Limited Warranty located in the product Installation and Operating Instruction Manual.**

Limitation of Liability. 3M Purification Inc. will not be liable for any loss or damage arising from this 3M Purification Inc. product, whether direct, indirect, special, incidental, or consequential, regardless of the legal theory asserted, including warranty, contract, negligence or strict liability. Some states and countries do not allow the exclusion or limitation of incidental or consequential damages, so the above limitation or exclusion may not apply to you.

Models: 3MPF201/3MPF301

SPECIFICATIONS

- Each system includes a head assembly with integral mounting bracket and a single replacement filter.
- Inlet and outlet plumbing connections are 1" NPT.
- Systems have a maximum operating pressure of 125 psi (862 kPa) and operating temperature of 100°F (37.8°C).
- Peak flow rate is up to 20 gpm (75.7 lpm).
- Replacement filter incorporates a non-woven blended pleat media (3MPF211).
- Replacement filter incorporates carbon block filtration with a non-woven blended pleat media (3MPF311HD).
- Replacement filters are sanitary in design, requiring no contact with the filter media during filter change-out.

IMPORTANT

⚠ WARNING: To reduce the risk associated with the ingestion of contaminants:

- **Do not use with water that is microbiologically unsafe or of unknown quality without adequate disinfection before or after the system.**

CAUTION: To reduce the risk associated with property damage due to water leakage:

- **Read and follow** Use Instructions before installation and use of this system.
- Installation and use **MUST** comply with all state and local plumbing codes.
- **Do not install** if water pressure exceeds 125 psi (862 kPa). If your water pressure exceeds 80 psi (552 kPa), you must install a pressure limiting valve. Contact a plumbing professional if you are uncertain how to check your water pressure.
- The disposable replacement filters **MUST** be replaced every 12 months, at the rated capacity or sooner if a noticeable reduction in flow rate occurs.

3M Purification Inc. recommends regularly scheduled maintenance and replacement of the replacement filter(s) in order for the product to perform as advertised. 3M Purification Inc. shall not be liable for system failures due to improper maintenance.